

TECHNICAL SPECIFICATIONS

Model	Power supply	Unit dimension (mm)	Net weight (kg)	Static pressure (Pa)	Air flow volume (m3/h)
AHRV-200/4	220V 50Hz	848X654X264	25	75	200
AHRV-300/4		926X722X270	27	75	300
AHRV-400/4		926X927X270	30	80	400
AHRV-500/4		1018X1024X270	41	80	500
AHRV-800/4		1274X1007X388	68	100	800
AHRV-1000/4		1274X1257X388	82	130	1000
AHRV-1500/5	380V 50Hz	1600X1270X540	200	160	1500
AHRV-2000/5		1650X1470X540	225	170	2000
AHRV-2500/5		1710X1400X600	240	180	2500
AHRV-3000/5		1700X1630X640	270	200	3000
AHRV-4000/5		1725X1450X1050	270	200	4000
AHRV-5000/5		1820X1780X1050	280	240	5000

Model	Cooling		Heating		Input power (W)	Running current (A)	Noise level dB(A)
	temperature efficiency	enthalpy efficiency	temperature efficiency	enthalpy efficiency			
AHRV-200/4	60	50	65	55	65	0.5	37
AHRV-300/4	60	50	65	55	120	0.6	39
AHRV-400/4	60	50	65	55	200	1.0	40
AHRV-500/4	60	50	65	55	220	1.0	41
AHRV-800/4	60	50	65	55	410	1.5	43
AHRV-1000/4	60	50	65	55	510	2.0	45
AHRV-1500/5	60	50	65	55	1000	4.4	52
AHRV-2000/5	60	50	65	55	1200	5.6	60
AHRV-2500/5	60	50	65	55	2000	6.8	62
AHRV-3000/5	60	50	65	55	2100	7.2	64
AHRV-4000/5	60	50	65	55	2400	8.2	66
AHRV-5000/5	60	50	65	55	3000	11.1	68

AUX AIR CONDITIONER

Total Heat Exchanger



AHRV-200/4
AHRV-300/4
AHRV-400/4

AHRV-500/4
AHRV-800/4
AHRV-1000/4



AHRV-1500/5
AHRV-2500/5
AHRV-4000/5

AHRV-2000/5
AHRV-3000/5
AHRV-5000/5

Thank you for choosing our Total Heat Exchanger. Please read this USER MANUAL carefully prior to using and keep it for further reference.

TABLE OF CONTENTS

Product Overview	1
Usage Guide	3
Installation Instruction	4
Maintenance and Service	8
Unit Dimension	9
Technical Specifications	10

UNIT DIMENSION

AHRV-200/4

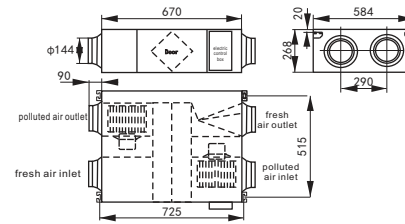

AHRV-300/4~AHRV-1000/4

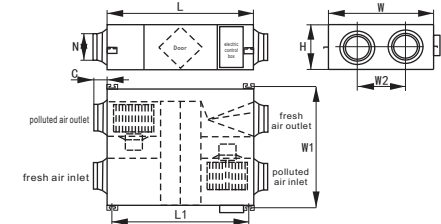

Model	L	L1	W	W1	W2	H	C	G	N
AHRV-300/4	748	675	603	657	315	274	100	19	φ 144
AHRV-400/4	748	675	808	862	480	274	100	19	φ 144
AHRV-500/4	828	754	908	960	500	274	107	19	φ 194
AHRV-800/4	1120	1045	888	940	428	392	85	19	φ 242
AHRV-1000/4	1120	1045	1138	1190	678	392	85	19	φ 242

AHRV-1500/5~AHRV-5000/5

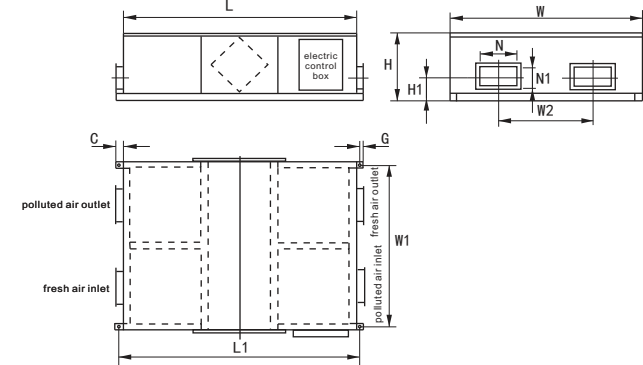

Model	L	L1	W	W1	W2	H	H1	C	G	N	N1
AHRV-1500/5	1500	1550	1230	1170	600	542	250	50	25	320	300
AHRV-2000/5	1550	1600	1430	1370	700	542	250	50	25	320	300
AHRV-2500/5	1610	1580	1370	1400	655	602	270	50	15	365	275
AHRV-3000/5	1700	1670	1540	1570	750	642	270	50	15	365	275
AHRV-4000/5	1625	1675	1365	1300	650	1052	510	50	25	370	330
AHRV-5000/5	1720	1675	1660	1630	810	1052	560	50	25	455	360

MAINTENANCE AND SERVICE

- Turn off the operation switch/special circuit breaker before maintenance and service.
- If the total heat exchanger is used for a long time, the performance of ventilation will decrease due to dirty or blocked filter. Clean the filter periodically as the accumulation of dust or debris on the heat exchanger core. Pay special attention in April to May if there are a lot of willow catkins flying in the sky, and they are more likely to attach with the filter, which will decrease the ventilation effect, so clean the filter 2 times every month during such period.
- Do not clean the filter and core of heat exchanger with volatile oil and metal brush.
- Do not clean the core of heat exchanger with water, please remove all the dust with a vacuum cleaner or brush. Do not clean the unit with water.

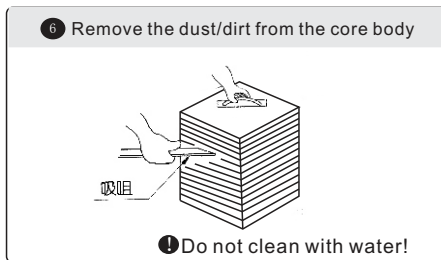
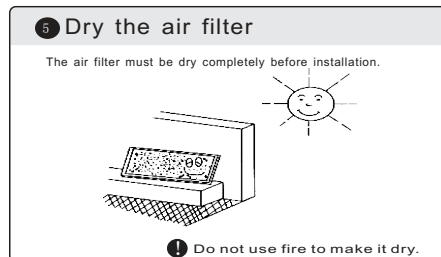
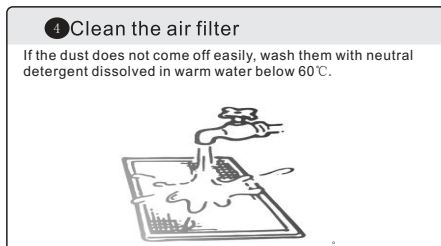
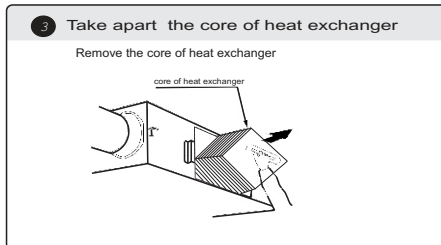
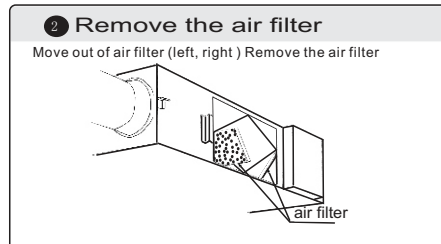
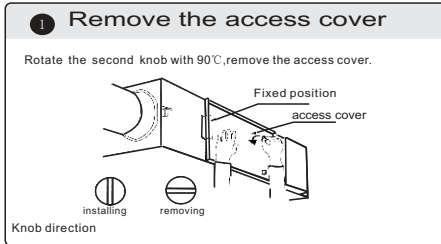

After cleaning, re-install the heat exchanger core and filter to their original state, and attach the access cover.

.8.

PRODUCT OVERVIEW

Total heat exchanger is energy-saving equipment used for the recovery of exhaust air energy from air-conditioner. Such device does not require the master air conditioner to provide cold and heat source but exchanges heat by means of directly recovery of the air in air-conditioner room. Therefore, it is the standard configuration of energy-saving and environmental-friendly, healthy buildings, and an ideal partner of air-conditioning. It is mainly composed of shell body, heat exchanger core and filters and other components. Such device works by following the principle that through the material with heat transfer and heat transmission performance in heat exchanger core, using exhaust air to pre-cool and dry the fresh air in summer and pre-heat and humidify fresh air in winter, so that the new fresh air load can be significantly reduced and thereby energy consumption and operating costs of heating and cooling system can be economized, and peak electricity consumption will also be reduced. Such device is widely used in high-rise buildings, hotels, office buildings, hospitals, shopping malls, and banks, residential buildings and other places.

Product Features

- **Energy-saving**
Effective recover the energy loss due to ventilation, save air conditioning operating cost.
- **Mute design, clean and fresh**
Unit has super silent design, free from maintenance and operation, thin and easy to install; and it is configured with filters to ensure the clean and fresh of fresh air and extend the service life of machine core.
- **Complete specification, for your choice at will**
This device is provided with serial design and complete function products, and thus can be widely applied into the independent space and realize energy-saving operation with full-fresh air.
- **Intelligent control, complete functions**
LCD intelligent controller is designed with refined and beautiful appearance, simplified structure, and one-button for multi-functional operation, and other features. The equipment running state on different time phase can be pre-set.
- **Novel structure, superior quality**
Through meticulous design, this unit is characterized by novel structure, elaborate craftsmanship, high-quality, and extremely delicate appearance.

Principle of GAE-type Total Heat Exchanger

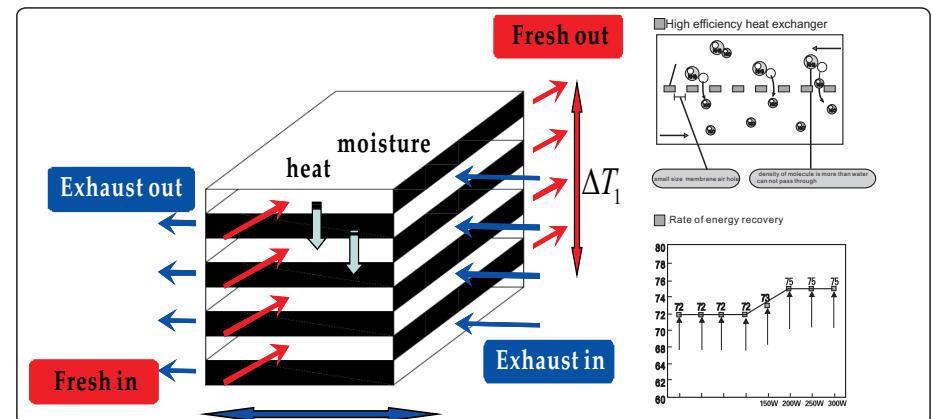

.1.

Sketch Diagram

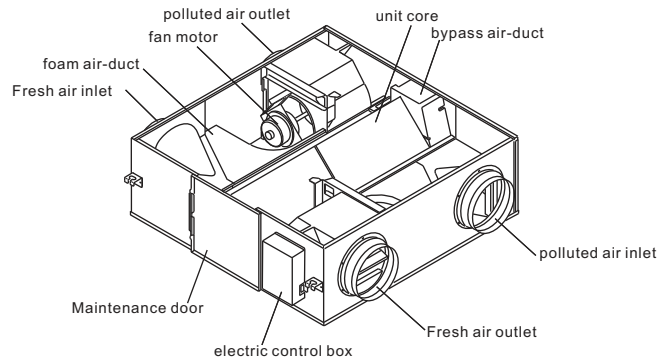

Selection Guide

Room type	No smoking				A little smoking		Lots of smoking	
	General ward	Stadium	Theater Department Store	Office	Computer room	Restaurant	Superior Room	Meeting Room
Fresh air volume per person Q(m ³ /h)	17-42	8-20	8.5-21	25-62	40-100	20-50	30-75	50-125
Number of room exchange fresh air P (Times/h)	1.06-2.65	0.50-1.25	1.06-2.66	1.56-3.90	2.50-6.25	1.25-3.13	1.88-4.69	3.13-7.81

Example

For a 60 square meter meeting room, net story height is 3m, ten person
 if required fresh air volume per person (Q) is 80, so $Q_1 = n \cdot q = 10 \times 80 = 800 (\text{m}^3/\text{h})$;
 if number of room exchange fresh air is 5.5 times/h, so $Q_2 = p \cdot s \cdot h = 5.5 \times 60 \times 3 = 990 (\text{m}^3/\text{h})$;
 Because $Q_2 > Q_1$, so adopt Q_2 as equipment selection base, you can choose our company product MURE-1000 type total heat exchanger whose air flow volume is 1000 m³/h.

WIRING

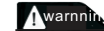

Please cut off the power supply before access to the appliance.

precautions

- Please install a breaker which can turn off the whole system power supply.
- Please install a switch to switch power supply.
- Make sure the grounding impedance is less than 100Ω. when using leakage circuit breaker, because you can use the earth resistance, so the grounding impedance can exceed 500Ω.
- Make sure the reliable grounding.
- Do not connect earth wire with a gas pipe, water pipe, lightning rod or a telephone earth wire.
- gas pipe: gas leakage will cause a fire.
- water pipe: If the material of water pipe is PE, it will not play a ground role.
- lightning rod or a telephone earth wire: the ground potential will be high when lightning.

Unit wiring diagram

single phase: AC 220V~/50Hz

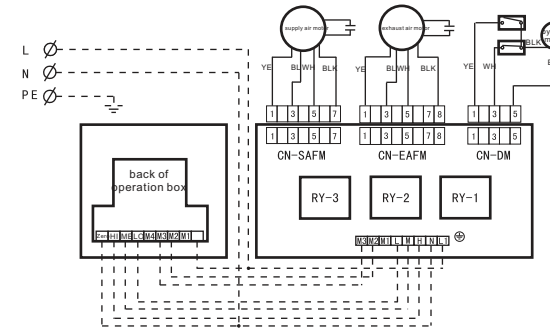

three phase: AC 380V~/50Hz

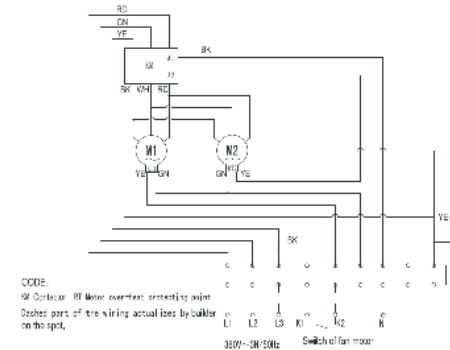

- Location in the following places may cause malfunction of the machine.

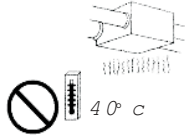
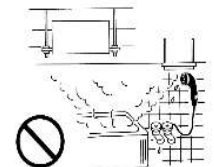
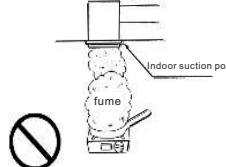
<p>Where direct sunshine or overheat.</p> <p>Do not install heat exchanger at the place where temperature is over 40°C, because air filter and core of heat exchanger will deform or damage the motor in the high temperature.</p> 	<p>humidity areas</p> <p>Do not install at the place where much moisture (such as bathroom), or may cause electric shock</p> 	<p>Where much fume(such as kitchen)</p> <p>Air filter and core of heat exchange attached the oil can not use.</p> 
<p>Ensure access door is easy to install the filter and maintenance the core of heat exchanger and unit.</p>		<p>Do not install the unit at the place where may have acids, alkalis, organic solvents coatings and other harmful gas or other corrosive gas.</p>

Installation of Drain Pipe

- Avoid pipe over bending/repeated bending and reducing the diameter of connecting pipe.
- When installing, outdoor pipes should slope downward to prevent water immersion.
- Insulating layer should be made to prevent condensation in outdoor pipe (if necessary, including the indoor pipe).
- The connection part of the pipeline should use aluminum tape to prevent gas leakage.
- Installation location of indoor supply air and inlet air should keep a distance as soon as possible.

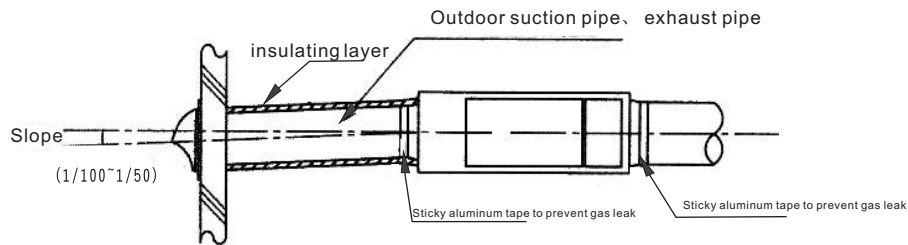

- When install the heat exchanger, the ceiling height must be guaranteed not less than the size of following table.

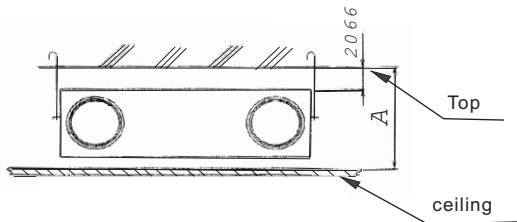

Model	Ceiling height A
LNRV-3X-D	262

.6.

USAGE GUIDE

Model:AHRV-200/4~AHRV-1000/4

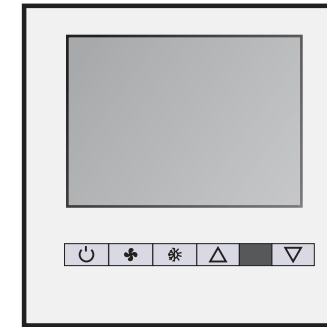

- ◆ON/OFF: Press "⏻" button once to turn on the unit, press it again to turn off the unit.
ON: the unit is running.
OFF: the unit stops, but the settings will save..
- ◆Fan motor control: Press "⚙️" button to choose fan speed.
"⚙️" high, "⚙️" middle, "⚙️" low.
- ◆Mode selection: when the heat exchanger is on, press button to select mode.
General ventilation: Press "⚙️" button until "⚙️" symbol is flashing, and automatically recognized 6 seconds later.
Heat recovery: Press "⚙️" button until "⚙️" symbol is flashing, and automatically recognized 6 seconds later.
- ◆Control for bypass motor: ①if the air volume is less than 1000, no bypass control ②if the air volume is more than 1000, you can press button to change between general ventilation and heat recovery, and then the bypass motor energized, the motor drive baffle movement, the LCD displays "⚙️" symbol. the bypass motor power off when the baffle moves to the setting location (about 12 seconds).
- ◆Adjust temperature: (only when the temperature is uncorrect)
Press button "▲" and "▼" for 3 seconds when the unit is off, the LCD displays "xx°C", press button "▲" and "▼" to adjust the temperature, and automatically recognized 6 seconds later.
- ◆when the power supply is 380V 3N~/50Hz, only has ON/OFF function.

Model:LNRV-15Q-D ~LNRV-50Q-W

Turn "OFF", total heat exchanger is stop.
Turn "ON", total heat exchanger is running.

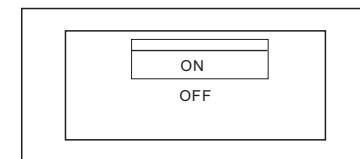

.3.

INSTALLATION INSTRUCTION

Safety Precautions

- Do not install the unit at the place where have heat resource or fire.
- Do not install the unit at the place where may have flammable gas leakage
- Do not install the unit at the lampblack place such as kitchen.
- Do not install the unit at the moisture place such as bathroom.
- Do not install the unit at the place where may have acids, alkalis, organic solvents coatings and other harmful gas or other corrosive gas
- Please install the access door at the air filter and core of heat exchanger side.
- The place must be solid and firm enough to bear the unit weight .
- Suggest installing leakage circuit breaker .
- Please install the unit at the inside of insulation .
- Inlet should be installed at the place where exhaust air can not regorge.
- Keep a clear distance between indoor suction port and indoor supply air port. choose the appropriate pipes.
- Fresh air suction pipe and exhaust air pipe should keep warm to prevent condensation
- Air inlet should install anti-bird net or similar device.
- Do not attempt to install by yourself. Ensure that instalation must be done by agent or authorized professional installation company.
- When using metal pipe through metal plate or metal mesh of the wooden buildings , it is necessary to do a insulation layer between the pipes and wall .

Installation Guide

Network connection figure of total heat exchanger and center air conditioner system

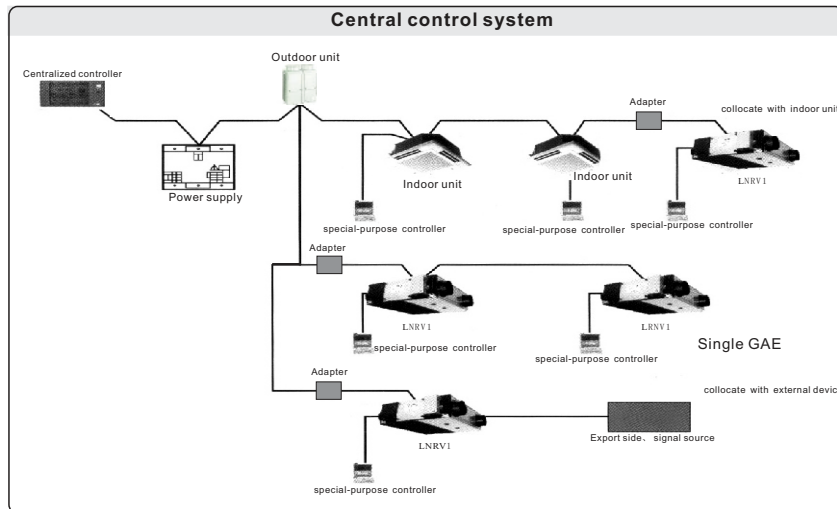

.4.

The Figure of Installation

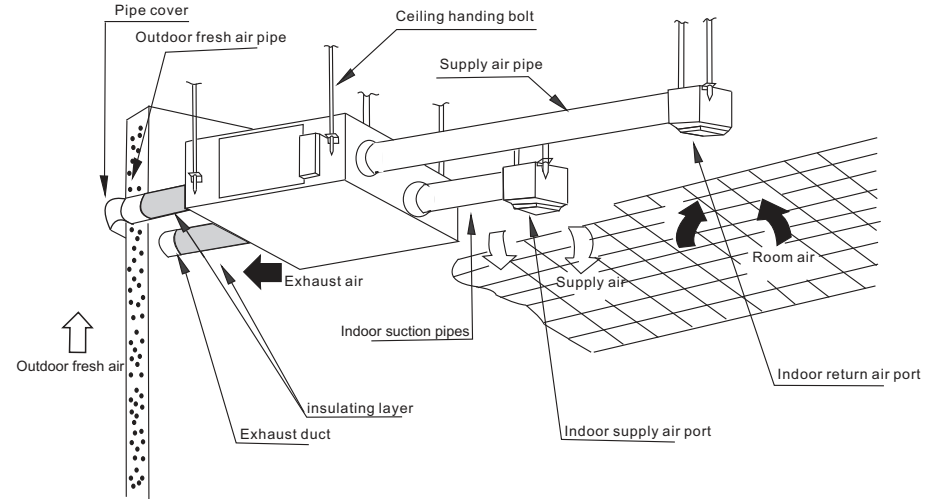

Two outdoor air dust should keep warm to prevent condensation

Installation Check

- First check whether the unit is complete and non-destructive before installation , and then open the panel, turn the fan by hand, check whether has the metal friction sound, if has, adjust the wheel to make it not touch the unit. please keep enough space for maintenance. Unit should be installed smoothly, and shall not bear the weight of condensate pipe and air-duct, connect the air duct and the air vent with soft connecting pipe. Power supply should be equipped with independent breaker as well as current leakage protective device. Make sure Reliable grounding and the power supply is 220V/50Hz or 380V/50Hz.

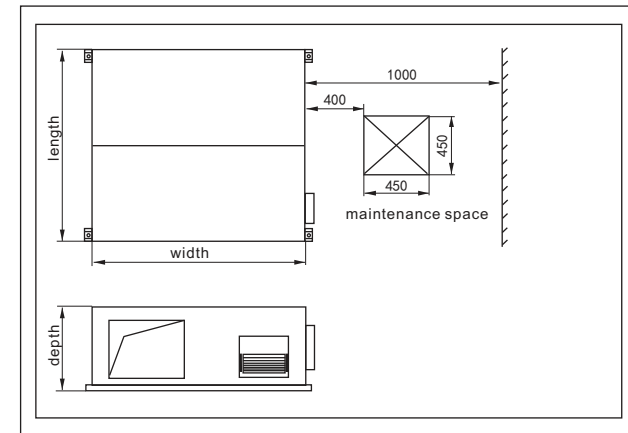

.5.