



压缩机技术规范
COMPRESSOR DATA SHEET

MAL QD91U HM
(220-240V~50Hz)

Hangzhou Comptek Compressor Manufacturing Co., Ltd.

索引 INDEX

	Page
1. 压缩机类型 Compressor Type	2
2. 性能参数 Performance Data	2
3. 运行工况 Running Condition	2
4. 压缩机机械信息 Compressor Mechanical Information	3
5. 残留物 Residue	3
6. 压缩机外形 Compressor Outline	4
7. 接线图 Wiring Diagram	5
8. 启动器与保护器 Starting Device and Motor Protector	6
9. 启动器与保护器外形图 Starting Device and Motor Protector Outline	6
10. 交货清单 Delivery list	7
11. 包装、贮存和运输 Package,Storage and Transportation	7
12. 附件示图 Accessories Diagram	8-10
13. 产品一般要求 General Requirement	11-12

压缩机技术规格书 COMPRESSOR DATA SHEET

1、压缩机类型 Compressor Type

压缩机型号 Compressor Model	MAL QD91U HM
额定电压/频率 Rated Voltage/Frequency	220-240V~50Hz
制冷剂 Refrigerant	R290
适用范围 Application	低中背压 L/MBP
冷却方式 Cooling Type	风冷却 Fan Cooling
节流装置 Expansion Device	毛细管/膨胀阀 Capillary/ expansion Valve
启动力矩 Start Torque	高启动转矩 High Starting Torque
电机类型 Motor Type	CSIR
启动电容 Starting capacitor	61μF/330V

2、技术参数 Technology Parameter

气缸容积 Displacement	技术参数 Technology Parameter					
	蒸发温度 Evaporating Temp.	频率(Hz) Frequency	制冷量 (W) Cooling capacity ≥ 95%	输入功率 (W) Input Power	工作电流 (A) Current	COP(W/W) ≥ 95%
9.3cm ³	-23.3℃	50Hz	450	310	2.0	1.45
	-6.7℃	50Hz	945	485	2.15	2.0
测试工况 Testing Conditions		ASHRAE				
		LBP	MBP			
蒸发温度 Evaporating Temp.		-23.3℃	-6.7℃			
环境温度 Ambient Temp.		32.2℃	35℃			
冷凝温度 Condensing Temp.		54.4℃	54.4℃			
吸气温度 Suction Temp.		32.2℃	35℃			
过冷温度 Sub-cooling Temp.		32.2℃	46.1℃			

3、运行工况 Running Condition

环境温度 Ambient Temp.	10~43℃
蒸发温度 Evaporating Temp.	-35~0℃
电压范围 Voltage Limits	187-255V~50Hz
最大排气压力 Max.Discharge Pressure	2.11MPa (abs)
最高冷凝温度 Max.Condensing Temp.	60℃
最高绕组温度 Max.Winding Temp.	130℃
最高壳体温度 Max.Shell Temp.	95℃
起动性能 Starting Performance	187V [0.85MPa]

4、压缩机机械信息 Compressor Mechanical Information

油类型 Oil Type	酯类油 Ester Oil
冷冻油黏度 Viscosity of Refrigeration Oil	CST32(40℃)
注油量 Oil Charging Volume	190±5ml
重量（含油） Weight (Including Oil)	9.1kg±0.15
吸气管直径（内径） Diameter of Suction Tube(I.D.) (S)	Φ6.2±0.1mm
排气管直径（内径） Diameter of Discharge Tube(I.D.) (D)	Φ4.9±0.1mm
工艺管直径（内径） Diameter of Process Tube(I.D.)(P)	Φ6.2±0.1mm
吸气管、工艺管、排气管材质 Material of Suction Tube,Process Tube and Discharge Tube	TP2
压缩机噪声 Compressor Noise	≦ 48dB (A) (LBP)
振动 Vibration	≦ 1.6m/s ² (LBP)
保护气体 Protecting Gas	干燥氮气（0.03~0.06MPa(露点：-60℃) Dry nitrogen（0.03~0.06MPa(Dew point:-60℃)
接水盘挂钩 Water Collector Fixture	无 No
密封 Sealing	橡胶塞 Rubber Plug

5、残留物 Residue

含水量 Water Content	≦ 130mg
残余杂质含量 Impurities	≦ 80mg

6、压缩机外形 Compressor Outline

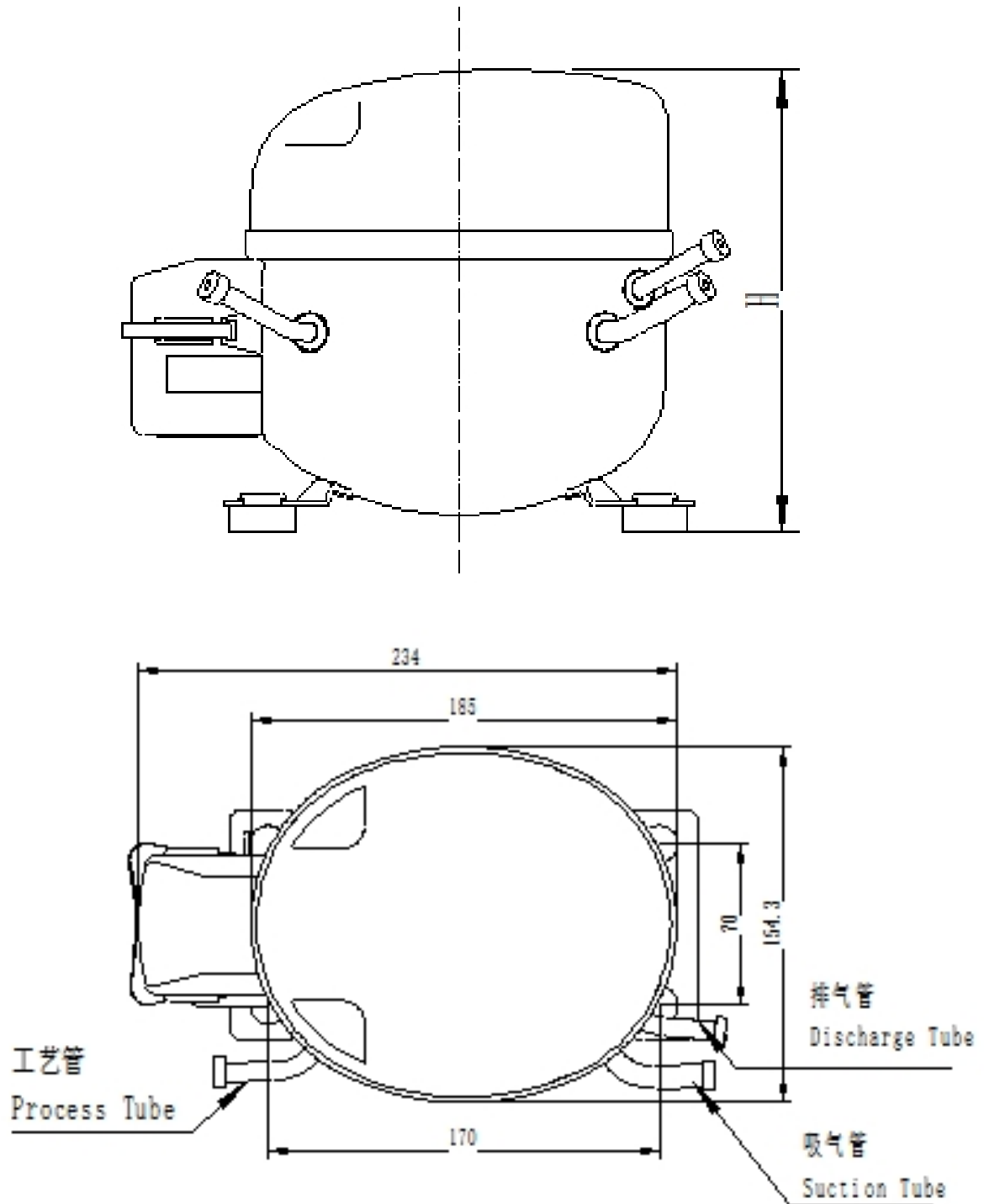

MAL QD91U HM	
H	204

7、接线图 Wiring Diagram

CSIR (CURRENT)

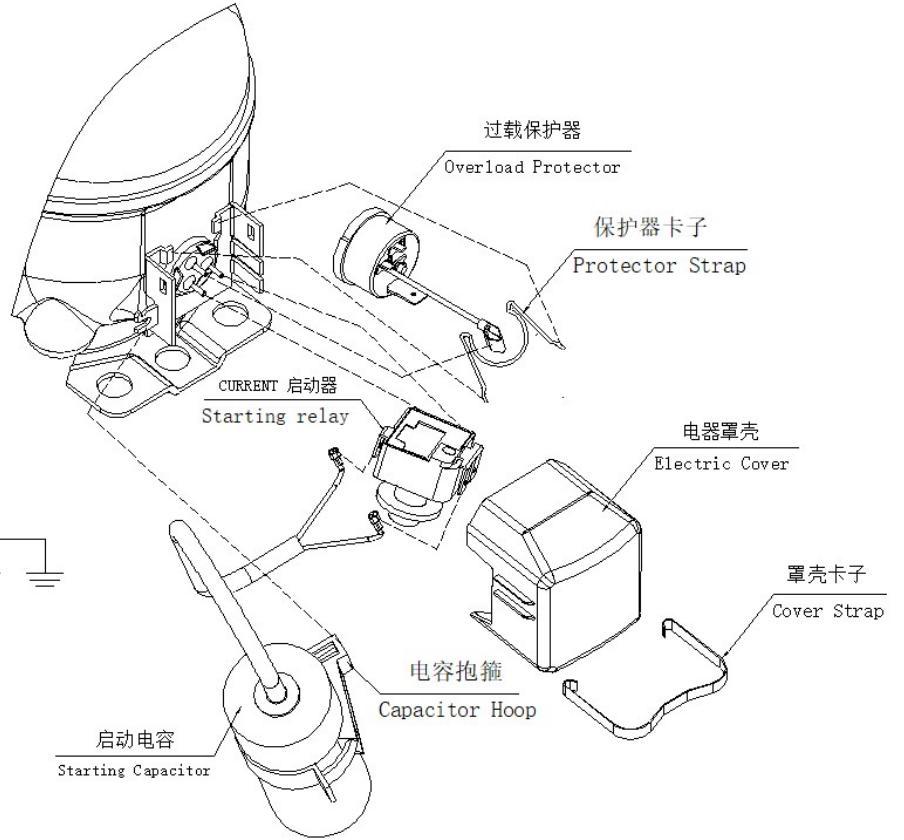
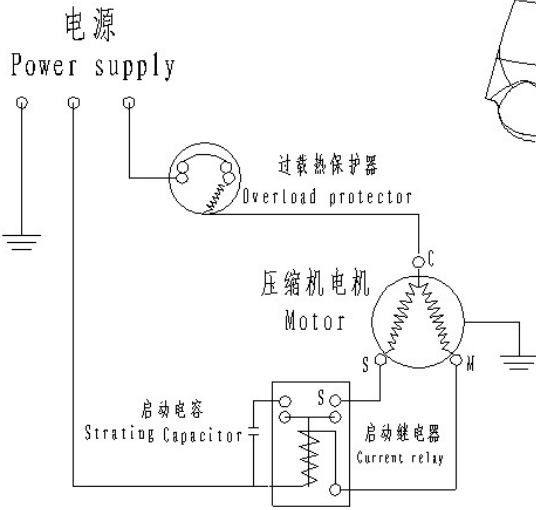

8、启动器与保护器 Starting Device and Motor Protector

8.1 启动器 Relay Starting Device

压缩机型号 Compressor Model	MAL QD91U HM
型号 Model	MTRP4115
吸合电流 Pick-up(A)	≤5.55
释放电流 Drop-out(A)	≥4.70

8.2 保护器 Motor Protector

压缩机型号 Compressor Model	MAL QD91U HM
型号 Model	T0884/B125/130
动作电流 Trip Current at (25°C)	12.5A
动作时间 Trip Time at (25°C)	6-16S
复位时间 Reset Time	30-180S
动作温度 Open Temperature	130±5°C
复位温度 Close Temperature	61±9°C
最小动作电流 U.T.C.(A) (70°C)	3.4±15%A

9、启动器与保护器外形图 Starting Device and Motor Protector Outline

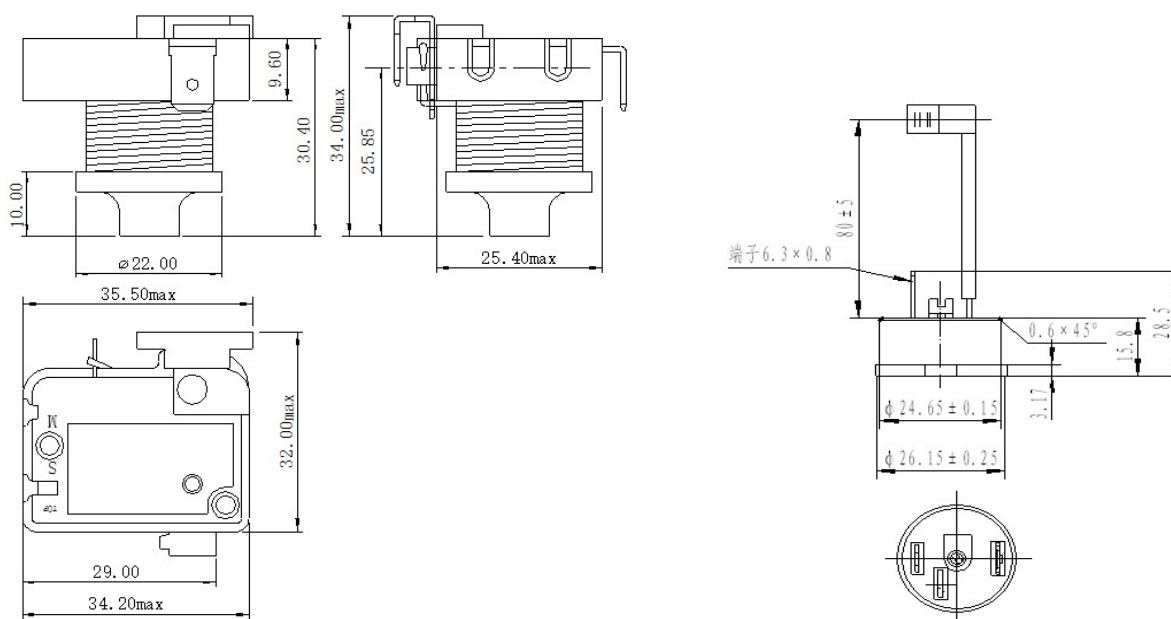

注：1、所有电器组件和安装部件是单独包装的，并不是直接安装在压缩机上；

2、交货清单下的所有电器组件和安装部件都由我公司提供；

Note: 1、 All electrical components and installation parts are individually packaged, not directly installed on the compressor.

2、 All electrical components and installation parts under the delivery list are provided by our company.

压缩机技术规格书 COMPRESSOR DATA SHEET

10、交货清单 Delivery List

序号 No.	名称 Name	规格 Specifications	数量 Quantity
1	压缩机 Compressor	MAL QD91U HM	1
2	安装附件 Installation parts		
2.1	减振垫 Rubber shock bsorber		4
2.2	衬套 Spacer bush		4
3	电器附件 Electrical components		
3.1	过载热保护器 Motor protector		1
3.2	保护器卡子 Protector strap		1
3.3	启动器 Relay starting device		1
3.3	启动电容 Starting capacitor		1
3.4	电容抱箍 Capacitor hoop		1
3.5	电器罩壳 Electrical components cover		1
3.6	罩壳卡子 Spring clip for Electrical components cover		1
3.7	接地螺钉(含垫片)Grounding screw (including washers)	M4×6	1

11、包装、贮存和运输 Package, Storage and Transportation

包装类型 Package type	一次性 Single use
数量 Quantity	96/120 台/托 96/120Pcs/pallet
运输 Transportation	海运或陆运 Sea or land transportation
堆码层数 Stacking layer	最多两层 At most two layers
主要包装组件 Main packing components	木底座、上盖板、小纸箱 Wooden supporter,upper wooden cover,Carton
搬运 Transfer	保持压缩机正常和垂直状态 Keep the compressor in normal and vertical position
模拟运输要求 Simulating transportation requirement	不允许对压缩机和性能有所损坏 No damage to compressor and its performance

12、附件示图（如下） Accessories Diagram as Below

1. 减振垫 Rubber shock absorber:

材质 Material	天然橡胶 Natural rubber
硬度 Hardness	邵氏 A55±5° ShoreA55±5°
颜色 Color	黑色 Black

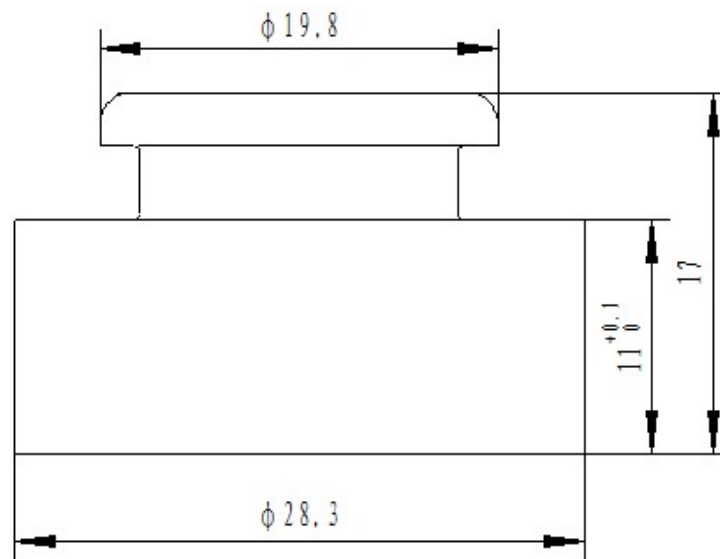

2. 衬套 Spacer bush:

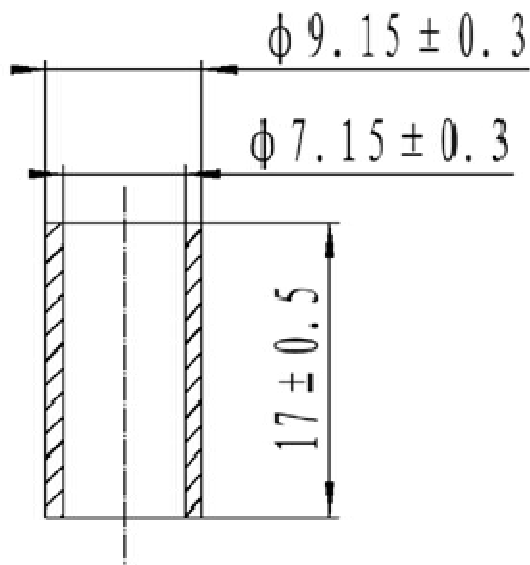

压缩机技术规格书 COMPRESSOR DATA SHEET

3. 电器罩壳 Electrical components cover:

材质 Material	ABS 0215F
证书 Certifications & Approvals	CQC14134120032

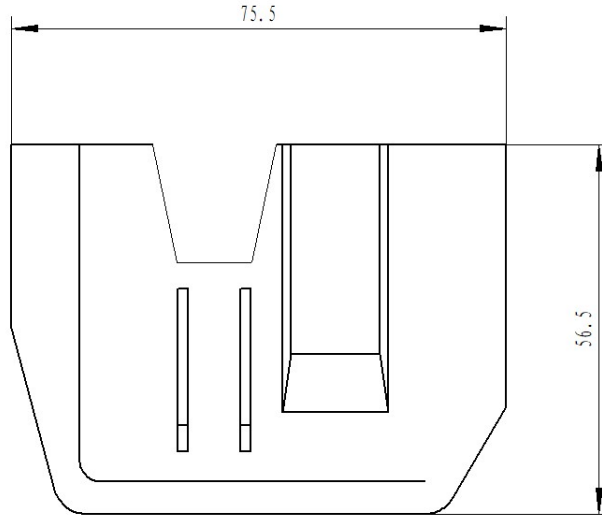

4. 接地螺钉 Grounding screw:

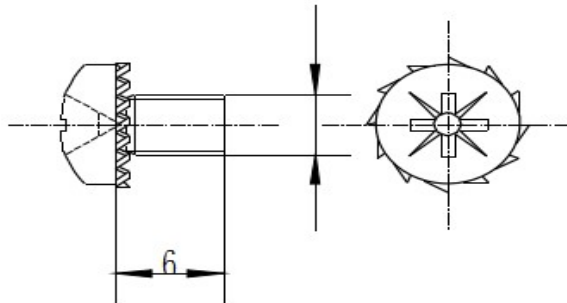

5. 罩壳外卡 Spring clip for Electrical components cover:

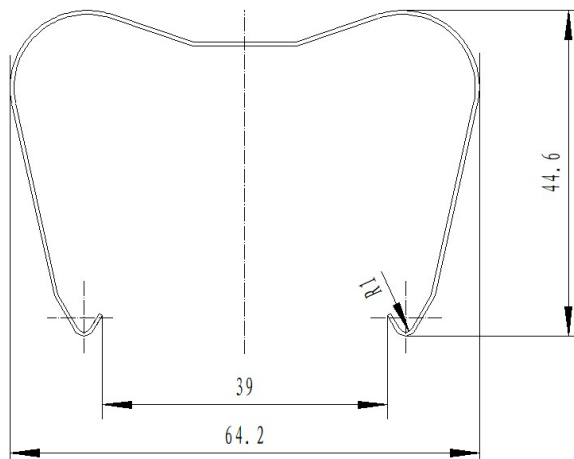

压缩机技术规格书 COMPRESSOR DATA SHEET

6.环保要求 Environmental protection requirements

- 1) PAHs 要求: PAHs (II类): BaP 含量 $<1\text{ppm}$ 、16种 PAH(EPA)总量 $<10\text{ppm}$;

Requirement of PAHs : PAHs (IIclass) : BaP content $<1\text{ppm}$, total content of 16PAH(EPA) $<10\text{ppm}$;

- 2) REACH 法规要求: SVHC 限制小于 1000ppm;

Regulatory requirement of REACH: SVHC $<1000\text{ppm}$;

- 3) 邻苯二甲酸盐(酯)要求: 18项有害物质限制要求小于 1000ppm。

Requirement of Phthalate: total content of 18 hazardous material $<1000\text{ppm}$.

- 4) ROHS 要求: Cd 含量 $<100\text{mg/kg}$ 、Pb 含量 $<1000\text{ mg/kg}$ 、Hg 含量 $<1000\text{ mg/kg}$

Regulatory requirement of ROHS: Cd $<100\text{mg/kg}$, Pb $<1000\text{ mg/kg}$, Hg $<1000\text{ mg/kg}$

13、产品一般要求 General Requirement

1. 压缩机应贮存于干燥通风的场所。
Compressor should be stored in a dry and drafty place.
2. 压缩机在储存、运输或安装过程中，不得翻转或倾斜，避免振动和冲击。
The compressor must not be turned or tilted during storage, transportation or installation to avoid vibration and impact.
3. 压缩机在运行时必须保持水平，倾斜角必须小于 5°。
The compressor must be kept level during operation, and the inclination angle must be less than 5°.
4. 压缩机安装前切勿将橡胶塞拔掉，以免杂物和潮气进入，安装时（建议先拔排气管橡胶塞）拔出橡胶塞后应在 10 分钟内安装完毕。
Rubber plugs should not be removed from tubes before installation so that avoid impurity and humidity. The installation should be completed within 10 minutes after that. (It is proposed to pull out the rubber plugs of discharge tube first of all.)
5. 压缩机的接地装置应永久可靠地与接地线连接。
The grounding device of the compressor should be permanently and reliably connected to the grounding wire.
6. 为了确保压缩机正常启动，压缩机运行间隔时间不得少于 5min。
In order to ensure the normal start of the compressor, the compressor running interval shall not be less than 5min
7. 压缩机内注有本公司认可的最佳量的专用冷冻机油，不得随意倒出或添加。
The charging volume of refrigeration oil has been optimized by our company. Don't pour any oil out or add.
8. 若压缩机附件（如启动器、热保护器等）交货时未安装在压缩机上，而是在附件箱内。安装时注意核对启动器、热保护器与压缩机的型号相对应。
If the compressor accessories (such as starters, motor protectors, etc.) are not installed on the compressor when they are delivered, they are in the accessory box. When installing, check that the starter, motor protector and compressor type correspond to each other.
9. 不要在真空状态下，启动运行压缩机及对压缩机施加高电压。压缩机不能用于对制冷系统抽真空。
Under vacuum, do not start and run the compressor, and do not apply high voltage to the compressor. The compressor cannot be used to vacuum the refrigeration system.
10. 压缩机工艺管和吸气管应按标识的指示连接，如需变动，需经本公司同意。
The compressor process tube and the suction tube should be connected according to the instructions of the mark. Any change shall be approved by the company.
11. 制冷系统设计时应充分考虑系统回油。
The oil return in system has been fully taken into consideration in design.
12. 压缩机运行的最高环境温度为 43℃。在最高环境温度 43℃ 下连续运行时，冷凝压力和峰值压力不应超过下表所示。
The maximum ambient temperature for compressor operation is 43° C. During continuous operation at the maximum ambient temperature of 43° C, the condensing pressure and peak pressure should not exceed those shown in the table below.

制冷剂 Refrigerant	R600a	R134a	R290
冷凝压力 Max.condensing pressure (MPa)	0.88	1.67	2.11
最大峰值冷凝压力 Max.Peak value condensing pressure (MPa)	1.09	2.09	2.57

压缩机技术规格书 COMPRESSOR DATA SHEET

13. 压缩机出厂后库存期最好不要超过 6 个月。如果超过请检查压缩机内干燥氮气是否充足，必要时应补充。
The stocking period must be less than 6 months after the date of production. If longer, you have to check whether the filled dry nitrogen is sufficient, and add it if necessary.
14. 抽真空和充注必须使用相应制冷剂的专用设备。
The vacuum pump and charging device must use special equipment for corresponding refrigerant.
15. 与制冷剂不相溶的有机物在制冷系统中不得使用。
Organic substances that are incompatible with refrigerants must not be used in the refrigeration system.
16. 制冷系统应使用与制冷剂相适应的干燥过滤器。
The refrigeration system should use a filter drier compatible with the refrigerant.
17. 制冷系统应严格控制水份、杂质、石蜡、硅油和氯离子等的含量。
The refrigeration system should strictly control the content of water, impurities, paraffin, silicone oil, and chloride ions.