

Large Axial Fans

630mm

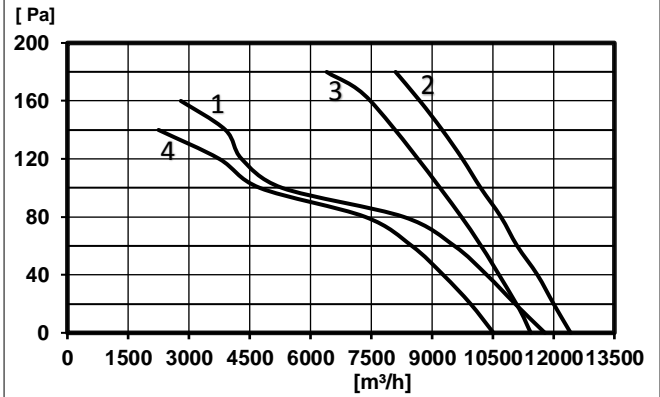

Bearing System : Ball
Material Blade : Sheet steel with powder coated
Material Of Guard Grill : Steel wire with powder coated
Type Protection : IP54
Motor Protection : Thermal Protection – (155°C)

Balancing Grade : G6.3 (Two Plane)
Mode Operation : Continuous Operation
Insulation Class : Class F
Operating Temperature: -30°C To +60°C
Product Life : 30,000 hours (At 40 °C)

Model	Voltage	Frequency	Current	Speed	Watt	Air Flow	Air Flow	Noise	Capacitor	Curve
	V AC	Hz	A	RPM	W	CFM	M3/h	dBA	µf	
4D-630	415	50	1.60	1320	815	7310	12420	75	-	2
6D-630	415	50	1.60	900	550	6936	11785	71	-	1
4E-630	230	50	3.5	1360	750	6730	11435	75	16	3
6E-630	230	50	2.55	900	520	6188	10515	71	12	4

Wiring diagram:

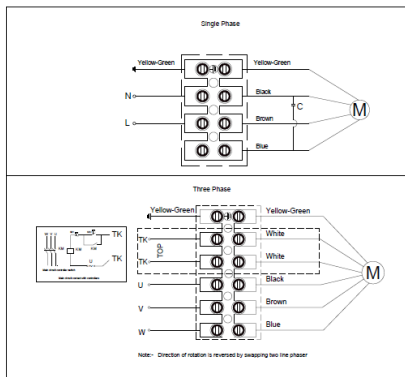

Drawing:

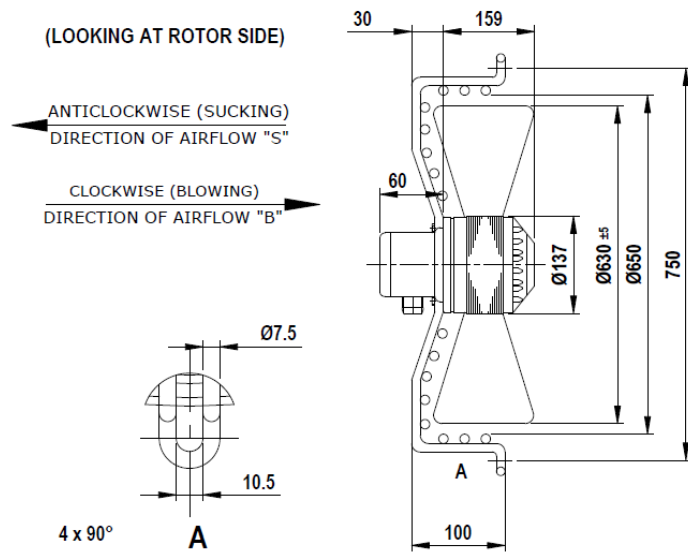

Note:-
 As Part of a green initiative, Hicool is constantly working to reduce power consumption without altering fan motor performance. Actual Current & Wattage readings can be lower than mentioned in datasheet & fan name plate.