

RoHS Compliant

REVISION: 02

UNIT:mm

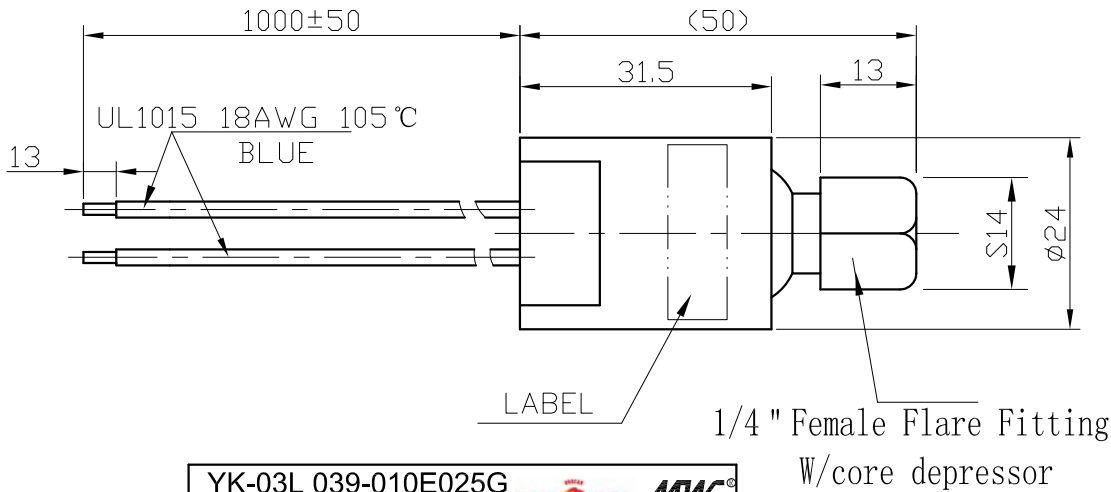

DATE CODE

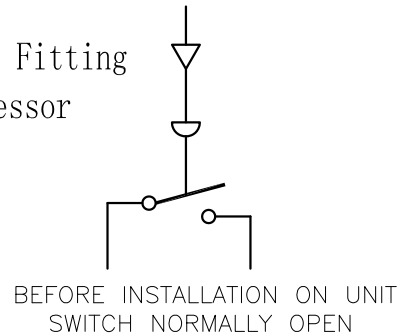

TECHNICAL SPECIFICATIONS

OPEN PRESSURE	10±5 PSI
CLOSE PRESSURE	25±7 PSI
TEST PRESSURE	250 PSI
BURST PRESSURE	5000 PSI
TEMPERATURE RANGE	Ambient: -30°C to +80°C Fluid: -50°C to +120°C
ELECTRICAL RATING	50/60Hz 250V 6A
INSULATION RESISTANCE	DC500V, LARGER THAN 100MΩ
CONTACT RESISTANCE BETWEEN TERMINALS	LESS THAN 50mΩ
DIELECTRIC STRENGTH	1550 VRMS terminals to fitting
UL RECOGNIZED	FILE SA13309,CCN SDFY8
CE RECOGNIZED	40000571
LIFE AT RATED LOAD	100,000 Cycles
SWITCH CONFIGURATION	SPST

Changzhou Match-well Pressure Control Technology Co.,Ltd.	CUSTOMER NAME:
	CUSTOMER P/N:
	Match-well P/N:YK-03H 039-010E025G
DRAWING DATE:September 12, 2019	Pressure Controls