

RoHS Compliant

REVISION: 02

UNIT:mm

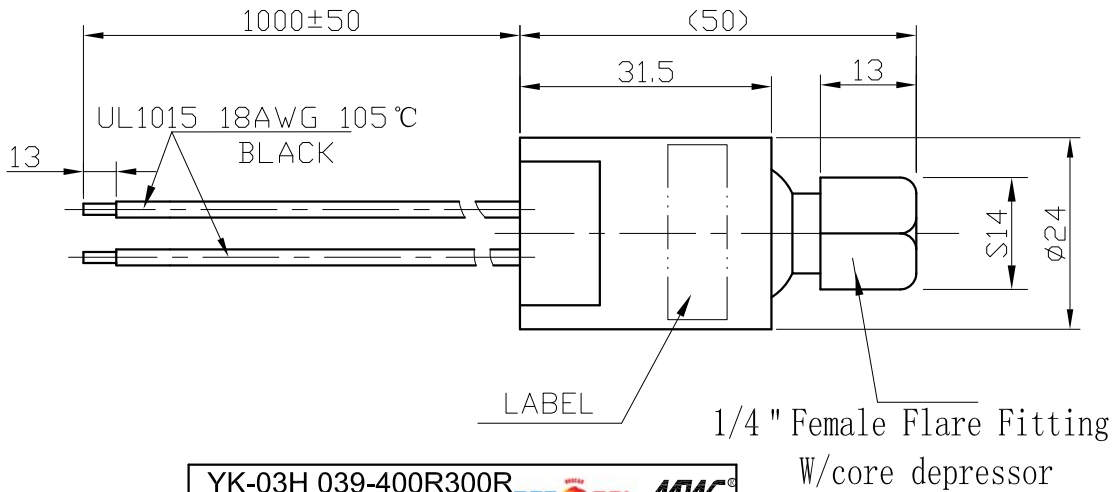

YK-03H 039-400R300R
 OPEN: 400 ± 15 PSI
 CLOSE: 300 ± 15 PSI
 XXXXXX 250V 6A

DATE CODE

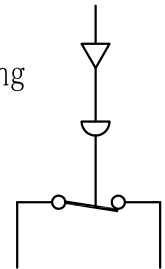

BEFORE INSTALLATION ON UNIT
 SWITCH NORMALLY CLOSED

TECHNICAL SPECIFICATIONS

OPEN PRESSURE	400 ± 15 PSI
CLOSE PRESSURE	300 ± 15 PSI
TEST PRESSURE	650 PSI
BURST PRESSURE	5000 PSI
TEMPERATURE RANGE	Ambient: -30°C to +80°C Fluid: -50°C to +120°C
ELECTRICAL RATING	50/60Hz 250V 6A
INSULATION RESISTANCE	DC500V, LARGER THAN 100MΩ
CONTACT RESISTANCE BETWEEN TERMINALS	LESS THAN 50mΩ
DIELECTRIC STRENGTH	1550 VRMS terminals to fitting
UL RECOGNIZED	FILE SA13309, CCN SDFY8
CE RECOGNIZED	40000571
LIFE AT RATED LOAD	100,000 Cycles
SWITCH CONFIGURATION	SPST

Changzhou Match-well Pressure Control Technology Co., Ltd.	CUSTOMER NAME:
	CUSTOMER P/N:
	Match-well P/N: YK-03H 039-400R300R
DRAWING DATE: September 12, 2019	Pressure Controls