



LIANG CHI INDUSTRY (THAILAND) CO., LTD.

COUNTER FLOW INDUCED DRAFT LBC TYPE COOLING TOWER SPECIFICATION

DATE :
 TOWER MODEL NO. : LBC - T - 225
 NO. OF SETS : 1

DESIGN & OPERATING CONDITIONS

WATER FLOW RATE. : 2,473 LPM
 HOT WATER TEMP. : 37 °C
 COLD WATER TEMP : 32 °C
 AMB. WET BULB TEMP. : 28 °C
 FAN B.H.P. : 6.25 BHP
 TOWER PUMP HEAD : 3.2 M
 DRIFT LOSS OF WATER FLOW RATE : 0.2 %
 EVAPORATION LOSS OF WATER FLOW RATE : 0.83 %
 DESIGN WIND LOAD : 150 Kg / M²

STRUCTURAL DETAILS

OVERALL DIMENSION : 3770 MM
 DRY WEIGHT : 960 Kg
 OPERATING WEIGHT PER TOWER : 3520 Kg

CONSTRUCTION

TOWER SUPPORTER FRAME ASS'Y : H.D.G.S.
 CASING : F.R.P.
 CASING SUPPORTOR : H.D.G.S.
 COLD WATER BASIN : F.R.P.
 FILLING : P.V.C.
 FILLING SUPPORTOR : H.D.G.S.
 FAN GUARD : H.D.G.S.
 MECHANICAL EQUIPMENT SUPPORTOR : H.D.G.S.
 INLET LOUVER : P.V.C.
 BOLTS,NUTS & WASHERS : C.P.S.

LIANG CHI IND. (THAILAND) CO., LTD.	
TECHNIC DEPT.	
<input type="checkbox"/>	FOR REFERENCE
<input checked="" type="checkbox"/>	FOR APPROVAL
<input type="checkbox"/>	APPROVED
<input type="checkbox"/>	OTHER.....
DATE :	
TECHNIC BY :	



LIANG CHI INDUSTRY (THAILAND) CO., LTD.

COUNTER FLOW INDUCED DRAFT LBC TYPE COOLING TOWER SPECIFICATION

WATER DISTRIBUTION

STAND PIPE : P.V.C.
 SPRINKLER HEAD : A.A.
 MODEL : LSH - 150
 SPRINKLER PIPE : P.V.C.

MECHANICAL EQUIPMENTS

FAN UNIT

NO. OF UNIT : 1 UNIT / SET
 TYPE : AXIAL FLOW
 MODEL : LSF-240
 MANUFACTUROR : LIANG CHI IND.CO.,LTD.
 DIAMETER : 2360 MM
 NO. OF BLADES : 4
 FAN SPEED : 398 RPM
 TIP SPEED : 49.18 M/S
 BLADE MATERIAL : A.A.
 HUP MATERIAL : A.A.
 AIR VOLUME : 1750 M³ / MIN/SET

SPEED REDUCER

NO. OF UNIT : 1 UNIT / SET
 TYPE : BELT
 MODEL : VBA-055-B
 MANUFACTUROR : LIANG CHI IND. CO.,LTD
 REDUCTION RATIO : 2.40 : 1

LIANG CHI IND. (THAILAND) CO., LTD.	
TECHNIC DEPT.	
<input type="checkbox"/>	FOR REFERENCE
<input checked="" type="checkbox"/>	FOR APPROVAL
<input type="checkbox"/>	APPROVED
<input type="checkbox"/>	OTHER.....
DATE :	
TECHNIC BY :	



LIANG CHI INDUSTRY (THAILAND) CO., LTD.

COUNTER FLOW INDUCED DRAFT LBC TYPE COOLING TOWER SPECIFICATION

FAN MOTOR

NO. OF UNIT : 1 UNIT / SET
 TYPE : TEFC
 INSULATION : CLASS F IP55
 MANUFACTUROR : LIANG CHI
 SPEED : 950 RPM
 RATED H.P : 7 1/2 H.P * 6 P
 POWER SOURCE (VOLT / PHASE / HZ) : 380 / 3 / 50

PIPING CONNECTION

	SIZE		Q'TY / SET
WATER INLET	6	B (150A)	1
WATER OUTLET	6	B (150A)	1
AUTO FILL	1 1/4	B (32A)	1
QUICK FILL	1 1/4	B (32A)	1
OVER FLOW	2	B (50 A)	1
DRAIN	2	B (50 A)	1

REMARK

F.R.P : FIBERGLASS REINFORCE PLASTIC

H.D.G.S : HOT DIP GALVALNIZED STEEL

A.A. : ALUMINIUM ALLOY

C.P.S. : CHROMATED - PLATING STEEL

DESIGNED : 

CHECK : 

APPROVE : 

LIANG CHI IND. (THAILAND) CO., LTD.	
TECHNIC DEPT.	
<input type="checkbox"/>	FOR REFERENCE
<input checked="" type="checkbox"/>	FOR APPROVAL
<input type="checkbox"/>	APPROVED
<input type="checkbox"/>	OTHER.....
DATE :	
TECHNIC BY :	

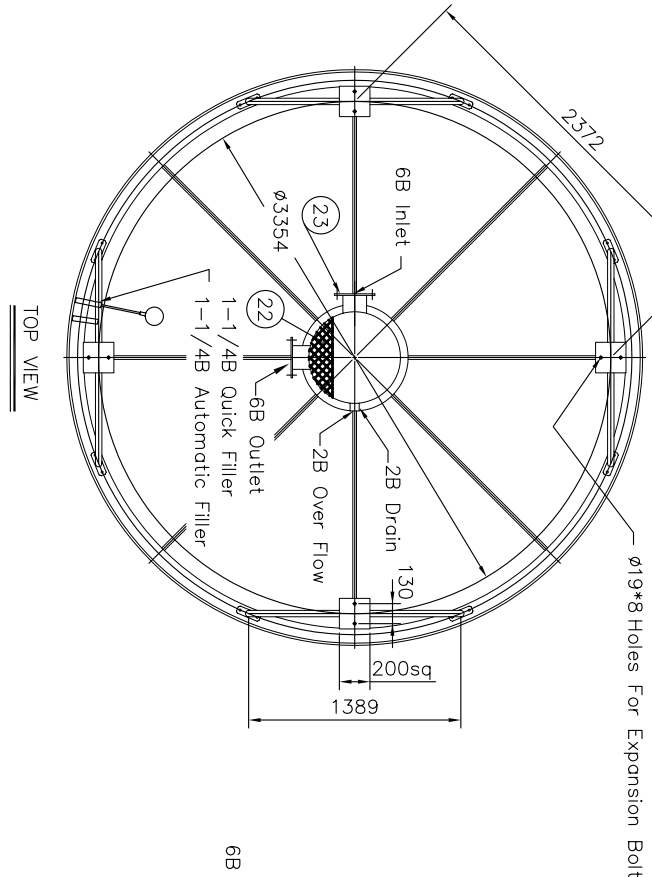
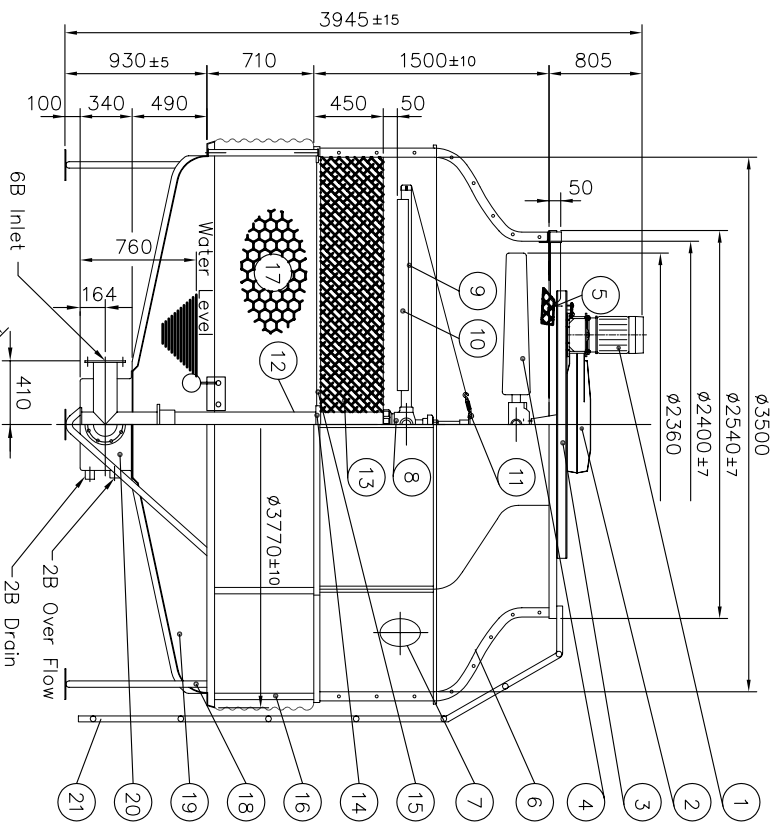

LIANG CHI IND. (THAILAND) CO.,LTD
 TECHNIC DEPT.
 FOR REFERENCE
 FOR APPROVAL
 APPROVAL
 OTHER.....
 DATE:
 TECHNIC BY:

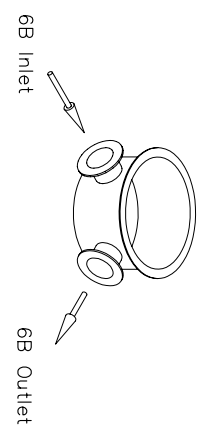

Description	M.T	Specification	Q'ty
1 Fan Motor		7 1/2HP*6P	1/pcs.
2 Belt Reducer		VBA-055-B	1/set.
3 Motor Framework Ass'y	H.D.G.S		1/pcs.
4 Fan	A.A	LSF-240	1/set.
5 Fan Guard	H.D.G.S		1/set.
6 Casing	F.R.P.		8/pcs.
7 Hand Hole	E.V.A		1/pcs.
8 Sprinkler Head	A.A	LSH-150	1/pcs.
9 Sprinkler Pipe	P.V.C.		4/pcs.
10 Eliminator	F.R.P.		4/pcs.
11 Tension Device	P.V.C.		4/set.
12 Stand Pipe	P.V.C.		1/pcs.
13 Filling	P.V.C.		1/set.
14 Stopper or Column	H.D.G.S		1/set.
15 Filling Supporter	H.D.G.S		1/set.
16 Casing Supporter	H.D.G.S		8/pcs.
17 Inlet Louver	P.V.C.		1/set.
18 Frame Ass'y	H.D.G.S		1/set.
19 Water Basin	F.R.P.		8/pcs.
20 Water Sump	F.R.P.		1/pcs.
21 Ladder	H.D.G.S		1/pcs.
22 Strainer	ST.S		1/pcs.
23 Flange	H.D.G.S		2/pcs.

Abbrev. : 1. H.D.G.S.: Hot Dip Galvanized Steel

2. A.A : Aluminum Alloy
3. ST.S : Stainless Steel 304
4. F.R.P. : Fiberglass Reinforced Plastic

Drain	50A (2 B)	Over Flow	50A(2 B)
Outlet	150A (6 B)	Quick Filler	32A(1 1/4 B)
Inlet	150A (6 B)	Automatic filler	32A(1 1/4 B)
Pipe Connections			
Dry Weight	960 kgs	Operating Weight	3,520 kgs
Loading Data			
Ambient Wetbulb	: 28 °C	Air Volume	: 1,750 M ³ /MIN
Outlet Water Temp	: 32 °C	Water Flow	: 2,473 LPM
Inlet Water Temp	: 37 °C	Cooling Capacity	: 741,900 Kcal/HR
Design Condition			

REV.	DATE	DWG BY	APP.	NOTE
TITLE				
LBC-T-225				
OUTLINE VIEW				
APP.	K.Sommons	DESIGN	Amnat	MM
CHECK	SURASAK	DWG BY	Amnat	DWG-NO
LIANG CHI INDUSTRY (THAILAND) CO., LTD. 223 Moo 9 Tab-Yaolad-Krabang Bangkok 10520 (NUM KRAL INDUSTRIAL ZONE LUANG-PAENG RD.)				
				LBC-T-225-01

EXPANSION BOLT (BY LIANG CHI)

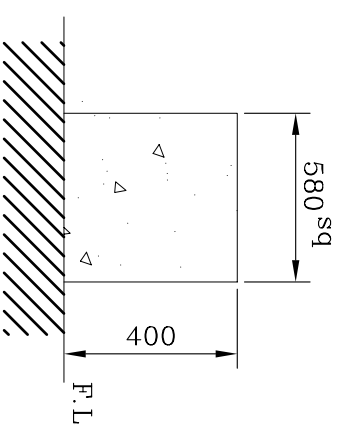
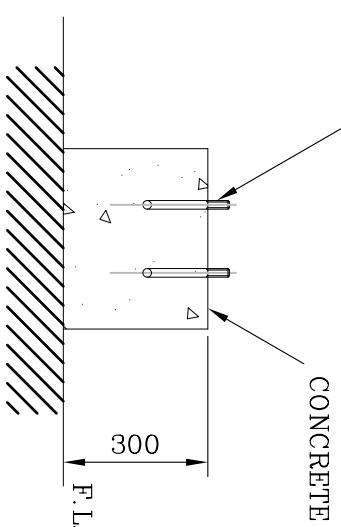
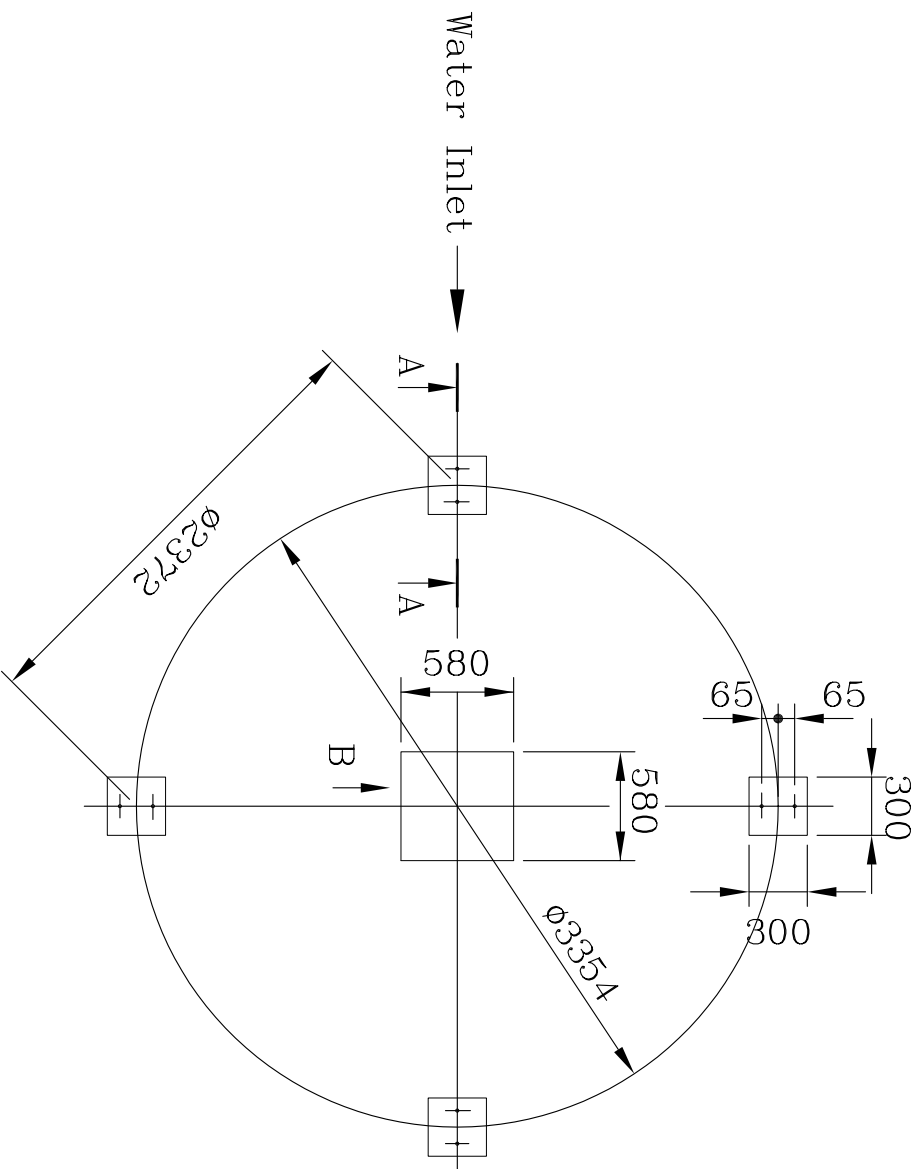

REMARK :

1. THIS FOUNDATION DRAWING IS PROVIDED FOR END USER'S REFERENCE.
2. COOLING TOWER DOES NOT INCLUDE FOUNDATION
3. THE LEVEL TOLERANCE OF FOUNDATION IS ±2 mm.
4. THE HEIGHT OF FOUNDATION EXCLUDES THERMAL INSULATOR AND WATER PROOF.
- * 5. EXPANSION BOLT & RUBBER PAD SHALL BE FURNISHED BY LIANG CHI
(PLEASE DON'T PREPARE HOLE OF EXPANSION BOLT BEFORE INSTALLATION)

LIANG CHI IND. (THAILAND) CO.,LTD
TECHNIC DEPT.

FOR REFERENCE
 FOR APPROVAL
 APPROVAL
 OTHER.....

DATE :
TECHNIC BY :

REV.	DATE	DWG BY	APP.	NOTE
TITLE				
Concrete Foundation				
APP.	K.Sommons	DESIGN	Annat	
CHECK	SURASAK	DWG BY.	Annat	
LIANG CHI INDUSTRY (THAILAND) CO., LTD. (NUM KRAL INDUSTRIAL ZONE LUANG-PAENG RD.)				
				MM
				DWG-NO
				LBC-T-225-02

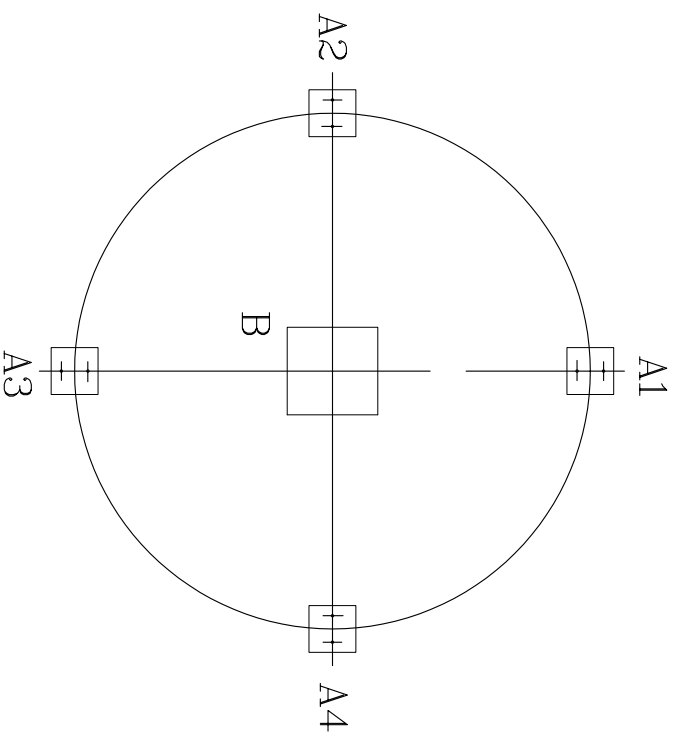

UNIT : KG.

LBC-T-225	A1=A2=A3=A4	B
	380	2,000

LIANG CHI IND. (THAILAND) CO.,LTD
 TECHNIC DEPT.
 FOR REFERENCE
 FOR APPROVAL
 APPROVAL
 OTHER.....
 DATE :
 TECHNIC BY :

REV.	DATE	DWG BY	APP.	NOTE
TITLE				
LBC-T-225				
Loading Data				
APP.	K.Sommons	DESIGN	Annat	
CHECK	SURASAK	DWG BY.	Annat	
LIANG CHI INDUSTRY (THAILAND) CO., LTD. (NUM KRAI INDUSTRIAL ZONE LUANG-PAENG RD.)				
				LBC-T-225-03