



# LIANG CHI INDUSTRY ( THAILAND ) CO., LTD.

## COUNTER FLOW INDUCED DRAFT LBC TYPE COOLING TOWER SPECIFICATION

DATE :  
 TOWER MODEL NO. : LBC - T - 15  
 NO. OF SETS : 1

### DESIGN & OPERATING CONDITIONS

WATER FLOW RATE. : 164 LPM.  
 HOT WATER TEMP. : 37 °C  
 COLD WATER TEMP : 32 °C  
 AMB. WET BULB TEMP. : 28 °C  
 FAN B.H.P. : 0.21 BHP  
 TOWER PUMP HEAD : 2 M  
 DRIFT LOSS OF WATER FLOW RATE : 0.2 %  
 EVAPORATION LOSS OF WATER FLOW RATE : 0.83 %  
 DESIGN WIND LOAD : 150 Kg / M<sup>2</sup>

### STRUCTURAL DETAILS

OVERALL DIMENSION : 1170 MM  
 DRY WEIGHT : 80 Kg  
 OPERATING WEIGHT PER TOWER : 260 Kg

### CONSTRUCTION

TOWER SUPPORTER FRAME ASS'Y : F.R.P.  
 CASING : F.R.P.  
 CASING SUPPORTOR : NYLON  
 COLD WATER BASIN : F.R.P.  
 FILLING : P.V.C.  
 FILLING SUPPORTOR : H.D.G.S.  
 MECHANICAL EQUIPMENT SUPPORTOR : H.D.G.S.  
 INLET LOUVER : P.V.C.  
 BOLTS,NUTS & WASHERS : C.P.S.

LIANG CHI IND. (THAILAND) CO., LTD.	
TECHNIC DEPT.	
<input type="checkbox"/>	FOR REFERENCE
<input checked="" type="checkbox"/>	FOR APPROVAL
<input type="checkbox"/>	APPROVED
<input type="checkbox"/>	OTHER.....
DATE :	
TECHNIC BY :	



# LIANG CHI INDUSTRY ( THAILAND ) CO., LTD.

## COUNTER FLOW INDUCED DRAFT LBC TYPE COOLING TOWER SPECIFICATION

### WATER DISTRIBUTION

STAND PIPE : P.V.C.  
 SPRINKLER HEAD : NYLON  
 MODEL : LSH - 050  
 SPRINKLER PIPE : P.E.

### MECHANICAL EQUIPMENTS

#### FAN UNIT

NO. OF UNIT : 1 UNIT / SET  
 TYPE : AXIAL FLOW  
 MODEL : LSF-070  
 MANUFACTUROR : LIANG CHI IND.CO.,LTD.  
 DIAMETER : 670 MM  
 NO. OF BLADES : 3  
 FAN SPEED : 945 RPM  
 TIP SPEED : 33.1 M/S  
 BLADE MATERIAL : NYLON  
 HUP MATERIAL : NYLON  
 AIR VOLUME : 135 M<sup>3</sup> / MIN/SET

#### FAN MOTOR

NO. OF UNIT : 1 UNIT / SET  
 TYPE : TEFC  
 INSULATION : CLASS F IP55  
 MANUFACTUROR : LIANG CHI  
 SPEED : 945 RPM  
 RATED H.P : 1/4 H.P \* 6P  
 POWER SOURCE ( VOLT / PHASE / HZ ) : 380 / 3 / 50

LIANG CHI IND. (THAILAND) CO., LTD.	
TECHNIC DEPT.	
<input type="checkbox"/>	FOR REFERENCE
<input checked="" type="checkbox"/>	FOR APPROVAL
<input type="checkbox"/>	APPROVED
<input type="checkbox"/>	OTHER.....
DATE :	
TECHNIC BY :	



# LIANG CHI INDUSTRY ( THAILAND ) CO., LTD.

## COUNTER FLOW INDUCED DRAFT LBC TYPE COOLING TOWER SPECIFICATION

<u>PIPING CONNECTION</u>		SIZE		Q'TY / SET
WATER INLET	:	2	B ( 50 A )	1
WATER OUTLET	:	2	B ( 50 A )	1
AUTO FILL	:	1/2	B ( 15 A )	1
QUICK FILL	:	1/2	B ( 15 A )	1
OVER FLOW	:	1	B ( 25 A )	1
DRAIN	:	1	B ( 25 A )	1

### REMARK

F.R.P : FIBERGLASS REINFORCE PLASTIC

H.D.G.S : HOT DIP GALVALNIZED STEEL

A.A. : ALUMINIUM ALLOY

C.P.S. : CHROMATED - PLATING STEEL

DESIGNED :  .....

CHECK :  .....

APPROVE :  .....

LIANG CHI IND. (THAILAND) CO., LTD.	
TECHNIC DEPT.	
<input type="checkbox"/>	FOR REFERENCE
<input checked="" type="checkbox"/>	FOR APPROVAL
<input type="checkbox"/>	APPROVED
<input type="checkbox"/>	OTHER.....
DATE :	
TECHNIC BY :	

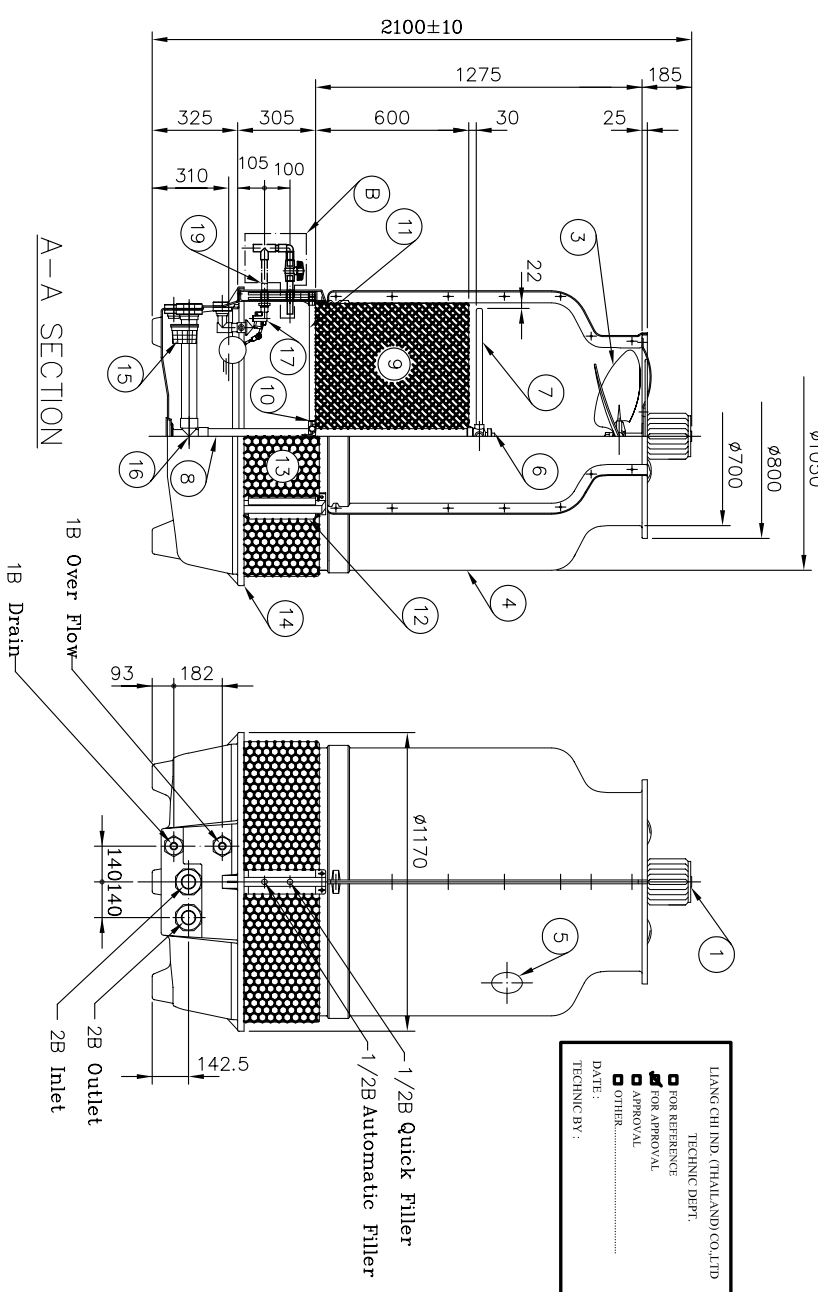
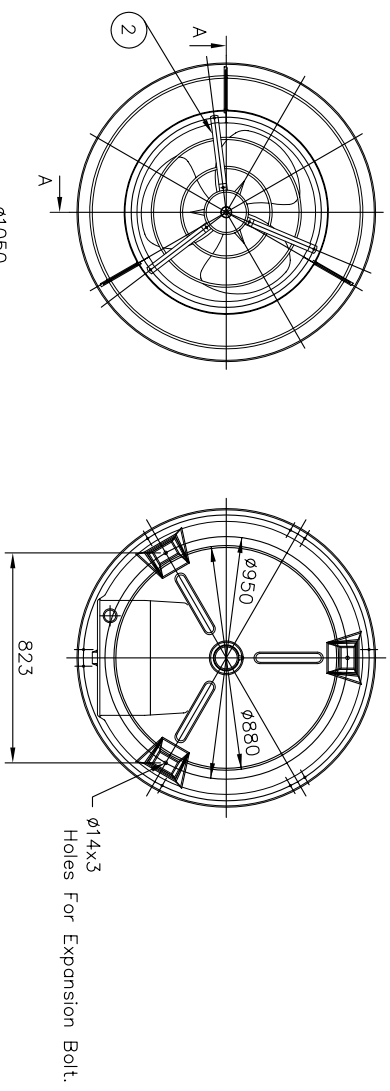

LIANG CHI IND. (THAILAND) CO., LTD  
 TECHNICAL DEPT.  
 FOR REFERENCE  
 FOR APPROVAL  
 APPROVAL  
 OTHER  
 DATE: .....  
 TECHNICIAN BY: .....

Note: The piping of Quick filler and Automatic filler (the part (B)) should be provided by customer.

Description	M.T	Specification	Q'ty
1 Fan Motor		1/4HP*6P	1 PCS
2 Motor Framework Ass'y	H.D.G.S		1 PCS
3 Fan	Nylon	LSF-070	1 SET
4 Casing	F.R.P.		3 PCS
5 Hand Hole	E.V.A.		1 PCS
6 Sprinkler Head	NYLON	LSH-050	1 PCS
7 Sprinkler Pipe	P.E.		4 PCS
8 Stand Pipe	P.V.C.		1 PCS
9 Filling	P.V.C.		1 SET
10 Stopper or Column	A.A.		1 SET
11 Filling Supporter	H.D.G.S		1 SET
12 Casing Supporter	NYLON		3 PCS
13 Inlet Louver	P.V.C.		1 SET
14 Water Basin	F.R.P.		1 PCS
15 Strainer	P.E.		1 PCS
16 Stand Pipe Base	P.V.C.		1 SET
17 Float Valve Ass'y	P.E.		1 SET
18			
19 Connector	P.V.C.		1 PCS
20			

Drain	25A ( 1 B)	Over Flow	25A (1B)
Outlet	50A ( 2 B)	Quick Filler	15A (1/2B)
Inlet	50A ( 2 B)	Automatic Filler	15A (1/2B)
Pipe Connections			
Dry Weight	80 kgs	Operating Weight	260 kgs
Loading Data			
Ambient Wetbulb	: 28 °C	Air Volume	: 135 M <sup>3</sup> /MIN
Outlet Water Temp	: 32 °C	Water Flow	: 164 LPM
Inlet Water Temp	: 37 °C	Cooling Capacity	: 49,200 Kcal/HR
Design Condition			
REV.	DATE	DWG BY	APP.
LBC-T-15			
TITLE			
OUTLINE VIEW			
APP.	K.Somanas	DESIGN	Arnat
CHECK	SURASAK	DWG BY.	Arnat
LIANG CHI INDUSTRY (THAILAND) CO., LTD. 223 Moo 9 Tab-Xo-Lad-Krabang Bangkok 10520 (NUM KRAL INDUSTRIAL ZONE LUANG-PAENG RO.)			LBC-T-15-01

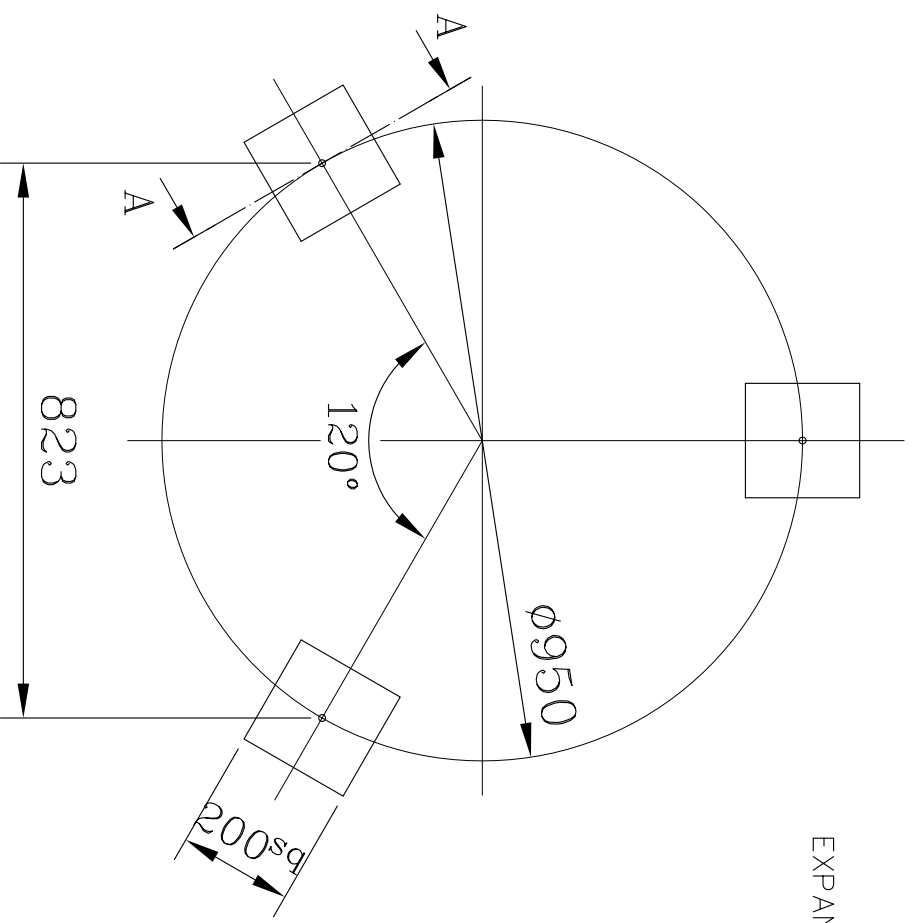

EXPANSION BOLT ( BY LIANG CHI )

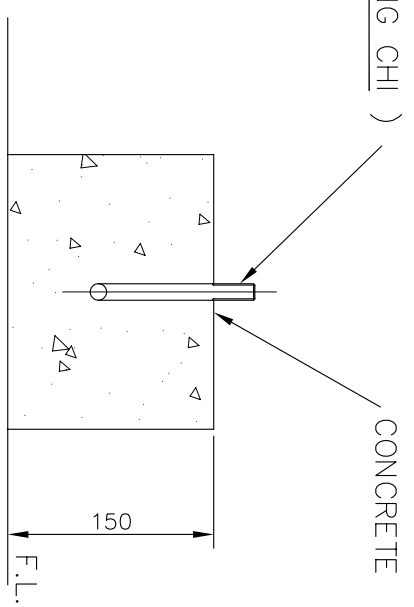

A-A SECTION

REMARK :

1. THIS FOUNDATION DRAWING IS PROVIDED FOR END USER'S REFERENCE.
2. COOLING TOWER DOES NOT INCLUDE FOUNDATION
3. THE LEVEL TOLERANCE OF FOUNDATION IS ±2 mm.
4. THE HEIGHT OF FOUNDATION EXCLUDES THERMAL ISOLATOR AND WATER PROOF.
- \* 5. EXPANSION BOLT & RUBBER PAD SHALL BE FURNISHED BY LIANG CHI  
( PLEASE DON'T PREPARE HOLE OF EXPANSION BOLT BEFORE INSTALLATION )

LIANG CHI IND. (THAILAND) CO.,LTD  
TECHNIC DEPT.  
 FOR REFERENCE  
 FOR APPROVAL  
 APPROVAL  
 OTHER.....  
 DATE: .....  
 TECHNIC BY :

Water Inlet

REV.	DATE	DWG BY	APP.	NOTE
TITLE		Concrete Foundation		
APP.	K.Somnons	DESIGN	Amnat	MM
CHECK	SURASAK	DWG BY	Amnat	DWG-NO
LIANG CHI INDUSTRY (THAILAND) CO., LTD. 223 Moo 9 Tab-Yaolad-Krabang Bangkok 10520 (NUM KRAI INDUSTRIAL ZONE LUANG-PAENG RD.)				LBC-T-15-02

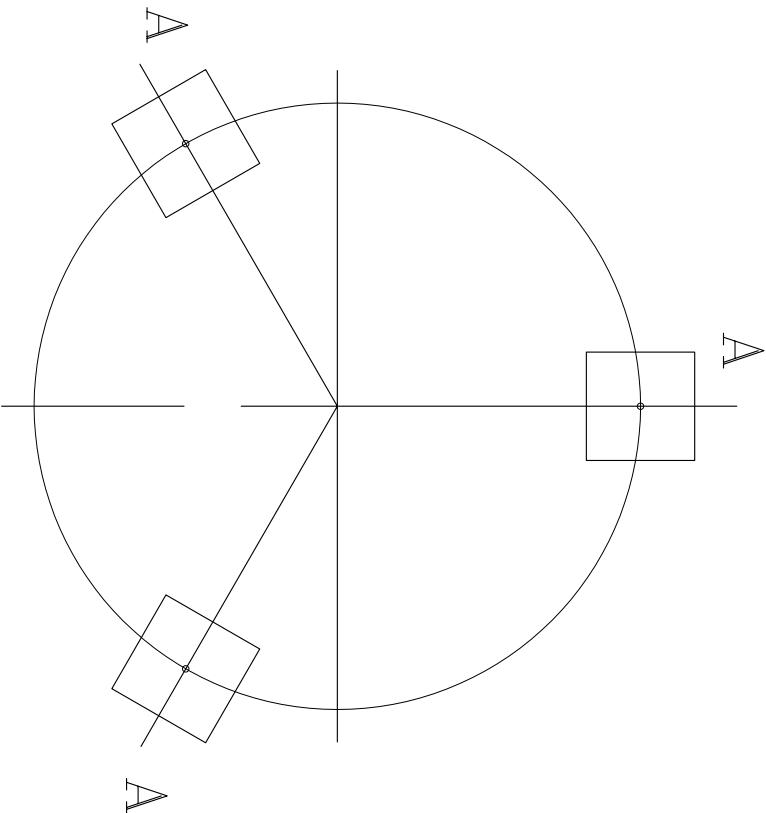

LBC-T-15	A
	86.7

UNIT : KG.

LIANG CHI IND. (THAILAND) CO.,LTD  
 TECHNIC DEPT.  
 FOR REFERENCE  
 FOR APPROVAL  
 APPROVAL  
 OTHER.....  
 DATE :  
 TECHNIC BY :

REV.	DATE	DWG BY	APP.	NOTE
TITLE				
LBC-T-15				
Loading Data				
APP.	K.Somnong	DESIGN	Amnat	MM
CHECK	SURASAK	DWG BY	Amnat	MM
LIANG CHI INDUSTRY (THAILAND) CO., LTD. 223 Moo 9 TAB-YAO LAD-KRABANG BANGKOK 10520 (NUM KRAI INDUSTRIAL ZONE LUANG-PAENG RD.)				
				LBC-T-15-03